

ΚΛΙΜΑΤΙΣΤΙΚΑ ΣΥΣΤΗΜΑΤΑ
AIR CONDITIONING SYSTEMS

Models: COOL

Portable Air Conditioner
Owner's Manual

Φορητό Κλιματιστικό
Εγχειρίδιο Χρήσης

Σας ευχαριστούμε που επιλέξατε το φορητό κλιματιστικό INVENTOR. Για τη σωστή χρήση της μονάδας παρακαλούμε διαβάστε προσεκτικά το παρόν εγχειρίδιο και φυλάξτε το για αναφορά στο μέλλον.

Thank you for choosing INVENTOR air conditioning system. For correct use of this unit, please read this manual carefully and keep it for future reference.

English/Ελληνικά/Română

 **inventor**[®]
Your-conditions

Content

Operation Notices

Operation environment.....	1
Safety warning.....	2
Part's Name.....	3

Operation Guide

Operation introduction for control panel	4
Buttons on remote controller	6
Introduction for icons on display screen	6
Introduction for buttons on remote controller.....	7
Function introduction for combination buttons.....	9
Operation guide	9
Replacement of batteries in remote controller.....	10

Maintenance

Clean and Maintenance.....	11
----------------------------	----

Malfunction

Malfunction analysis	13
----------------------------	----

Installation Notice

Installation Precaution	16
Preparation before installation.....	17

Installation

Install drainage pipe	18
Installation and disassembly of heat discharge pipe	19
Operation test.....	22

Attached sheet

Drainage way.....	22
Electric schematic diagram.....	23



This marking indicates that this product should not be disposed with other household wastes throughout the EU. To prevent possible harm to the environment or human health from uncontrolled waste disposal, recycle it responsibly to promote the sustainable reuse of material resources. To return your used device, please use the return and collection systems or contact the retailer where the product was purchased. They can take this product for environmental safe recycling.

R410A(R32/125: 50/50): 2087.5

Operation environment

- The air conditioner must be operated with in the temperaturerange: 16°C ~ 35°C.
- The appliance is for indoor use only.
- The appliance must be positioned so that the plug is accessible.
- This air conditioner can only be used for family, not for commercial industry.
- Reserved space around the air conditioner should be 12"(30cm) at least.
- Do not operate the air conditioner at humid environment.
- Please keep air inlet and air outlet clean, no obstacles.
- During operation, close doors and windows to improve cooling effect.
- Please put the air conditioner at smooth and flat ground for operation to avoid noise and vibration.
- This air conditioner is equipped with castors. Castors should slide at smooth and flat ground.
- Prohibit inclining or turn over the air conditioner. If there's abnormity, please disconnect power immediately and contact dealer.
- Avoid direct sunshine.

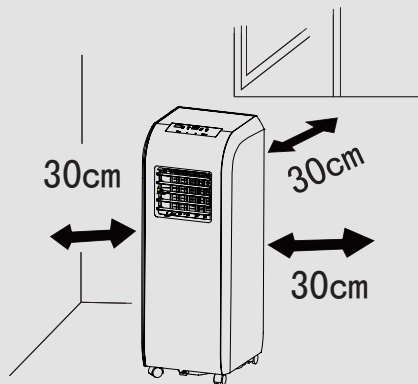

Safety warning

- This appliance can be used by children aged from 8 years and above and persons with reduced physical, sensory or mental capabilities or lack of experience and knowledge if they have been given supervision or instruction concerning use of the appliance in a safe way and understand the hazards involved. Children shall not play with the appliance. Cleaning and user maintenance shall not be made by children without supervision.
- Before operation, please confirm whether power specification complies with that on nameplate.
- Before cleaning or maintaining the air conditioner, please turn off air conditioner and pull out the power plug.
- Make sure the power cord hasn't been pressed by hard objects.
- Do not pull or drag the power cord to pull out the power plug or move the air conditioner.
- Do not insert or pull out the power plug with wet hands.
- Please use the grounded power. Make sure the grounding is reliable.
- If the supply cord is damaged, it must be replaced by the manufacturer or its service agent or a similarly qualified person in order to avoid a hazard.
- If the power cord is damaged, it must be replaced by manufacturer or professional person.
- If abnormal condition occurs (e.g. burned smell), please disconnect power at once and then contact local dealer.
- When nobody is taking care of the unit, please turn it off and remove the power plug or disconnect power.
- Do not splash or pour water on air conditioner. Otherwise, it may cause short circuit or damage to air conditioner.
- If use drainage hose, nearby temperature can't lower than 0°C. Otherwise, it will cause water leakage to air conditioner.
- Prohibit operating heating equipment around the air conditioner.
- Far away from fire source, inflammable and explosive objects.
- Children and disabled people are not allowed to use the dehumidifier without supervision.
- Keep children from playing or climbing on the air conditioner.
- Do not put or hang dripping objects above the air conditioner.
- Do not repair or disassemble the air conditioner by yourself.
- Prohibit inserting any objects into the air conditioner.

Part's Name

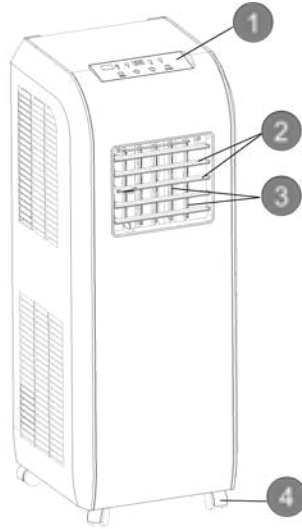

- 1 Controller panel
- 2 Guide louver
- 3 Swing louver
- 4 Wheel
- 5 Remote controller box
- 6 Power cord
- 7 Filters
- 8 Upper air inlet grille
- 9 Lower air inlet grille
- 10 Joint A
- 11 Heat removal pipe
- 12 Joint B
- 13 Joint C

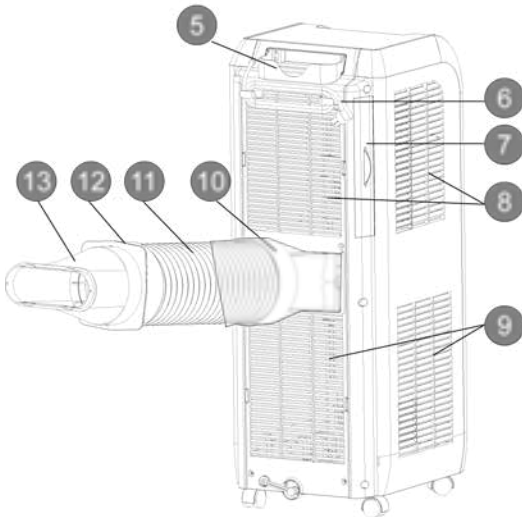

Remote controller

Note:

Heat-removal pipe and other installation accessories can't be discarded.

Operation introduction for control panel

Name of control panel

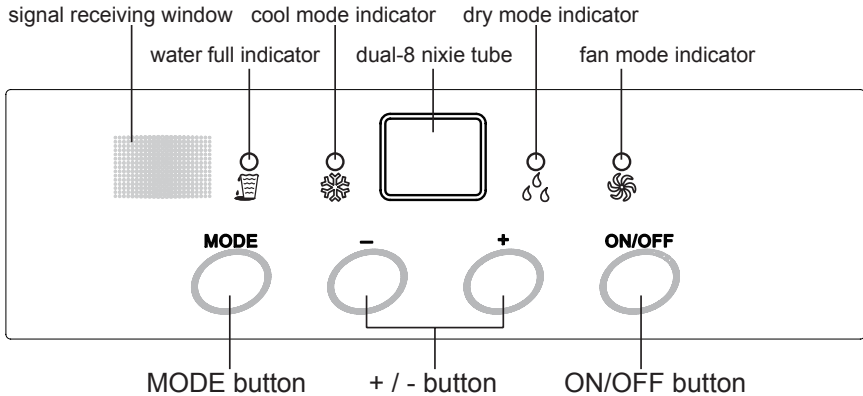

Operation of control panel

Note:

- After putting through the power, the air conditioner will give out a sound. After that, you can operate the air conditioner by the control panel.
- Under ON status, after each pressing of the button on control panel, the air conditioner will give out a sound. Meanwhile, corresponding indicator on control panel will be bright.
- Under OFF status, dual-8 nixie tube on control panel won't display. Under ON status, dual-8 nixie tube on control panel will display set temperature under cooling mode, while it won't display under other modes.

1 ON/OFF button

Press this button can turn on or turn off the air conditioner.

2 + / - button

Under cooling mode, press “+” or “-” button to increase or decrease set temperature 1°C(°F). Set temperature is range is 16°C(61°F)~30°C(86°F). Under auto, drying or fan mode, this button is invalid.

Operation introduction for control panel

3 MODE button

Press this button and the mode will circulate according to below sequence:
COOL→DRY→FAN

COOL: Under this mode, cooling mode indicator is bright. Dual-8 nixie tube displays set temperature. Temperature setting range is 16°C~30°C.

DRY: Under this mode, drying mode indicator is bright. Dual-8 nixie tube won't be display.

FAN: Under this mode, the air conditioner only blow fan. Fan indicator is bright. Dual-8 nixie tube won't be display.

4 water full indicator

when it twinkling, that means the water in the tank is full, we should drain off the water.

Note:

When the water in chassis is full, the unit will stop operation and the buzzer will give out eight "beep-beep" sounds for warning. In this case, water full indicator is blinking (off for 3s and blink for 8 times) and dual-8 nixie tube is displaying "H8".

Buttons on remote controller

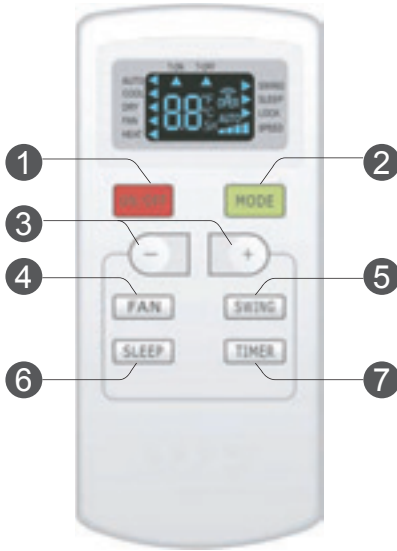

- ① ON/OFF button
- ② MODE button
- ③ +/- button
- ④ FAN button
- ⑤ SWING button
- ⑥ SLEEP button
- ⑦ TIMER button

Introduction for icons on display screen

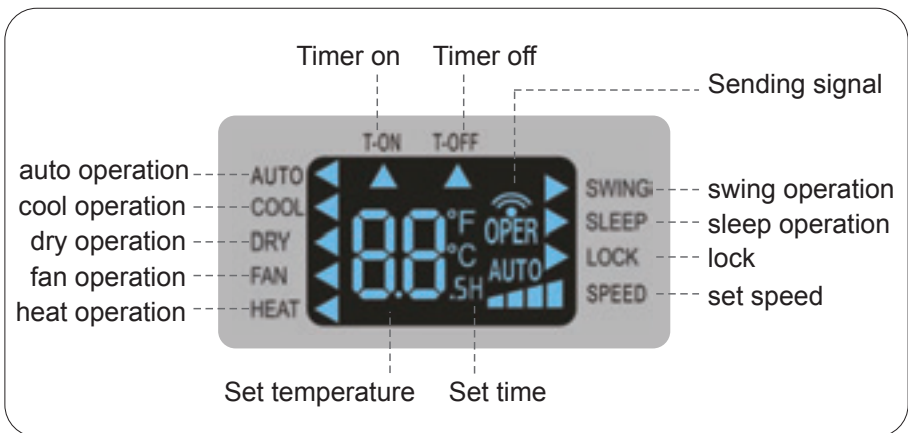

Introduction for buttons on remote controller

Note:

- When power is connected(stand by condition), you can operate the air conditioner through the remote controller.
- When unit is on, each time you press the button on remote controller, the sending signal icon "📶" on the display of remote controller will blink once. If the air conditioner gives out a beep sound, it means the signal has been sent.
- When unit is off, set temperature will be displayed on the remote controller (If the light of indoor unit display is turned on, the corresponding icon will be displayed); When unit is on, it will display the icon of the on-going function.

1 ON/OFF button

Press this button to turn unit on/off.

2 MODE button

Pressing this button once can select your required mode circularly as below (the corresponding icon "◀" will be lit up after the mode is selected):



- When selecting auto mode, air conditioner will operate automatically according to ambient temperature. Set temperature can't be adjusted and won't be displayed either. Press FAN button to adjust fan speed.
- When selecting cool mode, air conditioner will operate under cool mode. Then press + or - button to adjust set temperature. Press FAN button to adjust fan speed.
- When selecting dry mode, air conditioner will operate at low fan speed under dry mode. In dry mode, fan speed can't be adjusted.
- When selecting fan mode, air conditioner will operate in fan mode only. Then press FAN button to adjust fan speed.
- When selecting heat mode, air conditioner will operate under heat mode. Then press + or - button to adjust set temperature. Press FAN button to adjust fan speed. (Cooling only unit can't receive heating mode signal. If set HEAT mode by remote controller, press ON/OFF button can't turn on the air conditioner.)

3 + / - button

- Pressing + or - button once will increase or decrease set temperature by 1°F(°C). Hold + or - button for 2s, set temperature on remote controller will change quickly. Release the button after your required set temperature is reached.
- When setting Timer On or Timer Off , press + or - button to adjust the time.(See TIMER Button for setting details)

Introduction for buttons on remote controller

4 FAN button

Pressing this button can select fan speed circularly as: AUTO, SPEED 1 (▲), SPEED 2 (▲▲), SPEED 3 (▲▲▲), SPEED 4 (▲▲▲▲) (unavailable in this air conditioner. Speed 4 is the same with speed 3.).

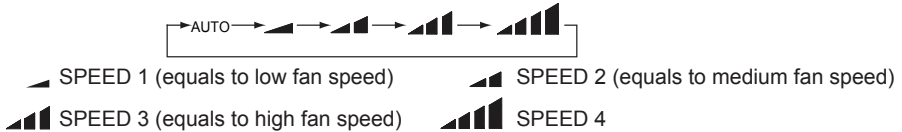

Note:

- Under Auto speed, air conditioner will select proper fan speed automatically according to ambient temperature.
- Fan speed can't be adjusted under Dry mode.

5 SWING button (not applicable for this model)

Press this button to turn on up&down air swing.

6 SLEEP button

Under Cool, Heat and Dry mode, press this button to turn on Sleep function. Press this button to cancel Sleep function. Under Fan and Auto mode, this function is unavailable.

7 TIMER button

- When unit is on, press this button to set Timer Off. T-OFF and H icon will be blinking. Within 5s, press + or - button to adjust the time for Timer Off. Pressing + or - button once will increase or decrease the time by 0.5h. Hold + or - button for 2s, time will change quickly. Release the button after your required set time is reached. Then press TIMER button to confirm it. T-OFF and H icon will stop blinking.
- When unit is off, press this button to set Timer On. T-ON and H icon will be blinking. Within 5s, press + or - button to adjust the time for Timer On. Pressing + or - button once will increase or decrease the time by 0.5h. Hold + or - button for 2s, time will change quickly. Release the button after your required set time is reached. Then press TIMER button to confirm it. T-ON and H icon will stop blinking.
- Cancel Timer On/Off: If Timer function is set up, press TIMER button once to review the remaining time. Within 5s, press TIMER button again to cancel this function.

Introduction for buttons on remote controller

Note:

- Range of time setting is: 0.5~24h
- The interval between two motions can't exceed 5s, otherwise the remote controller will exit setting status.

Function introduction for combination buttons

Child lock function

Press "+" and "-" buttons simultaneously can turn on or turn off child lock function. When child lock function is started up, LOCK indicator on remote controller is ON. If you operate the remote controller, remote controller won't send signal.

Temperature display switchover function

Under OFF status, press "-" button and "MODE" button simultaneously can switch between °C and °F.

Operation guide

1. After putting through the power, press "ON/OFF" button on remote controller to turn on the air conditioner.
2. Press "MODE" button to select your required mode: AUTO, COOL, DRY, FAN, HEAT.
3. Press "+" or "-" button to set your required temperature. (Temperature can't be adjusted under auto mode).
4. Press "FAN" button to set your required fan speed: auto, low, medium and high speed.

Replacement of batteries in remote controller

1. Press the back side of remote controller on the spot marked with "✎", and then push out the cover of battery box along the arrow direction.
2. Replace two No.7 (AAA 1.5V) dry batteries and make sure the positions of + and- polar are correct.
3. Reinstall the cover of battery box.

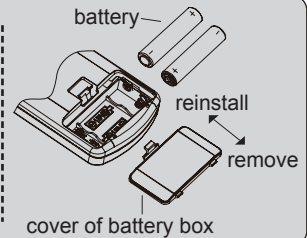

Note:

- During operation, point the remote control signal sender at the receiving window on indoor unit.
- The distance between signal sender and receiving window should be no more than 8m, and there should be no obstacles between them.
- Signal may be interfered easily in the room where there is fluorescent lamp or wireless telephone; remote controller should be close to indoor unit during operation.
- Replace new batteries of the same model when replacement is required.
- When you don't use remote controller for a long time, please take out the batteries.
- If the display on remote controller is fuzzy or there's no display, please replace batteries.

Clean and Maintenance



Warning:

- Before cleaning the air conditioner, please turn off the unit and disconnect power. Otherwise, it may cause electric shock.
- Do not wash air conditioner with water. Otherwise, it may cause electric shock.
- Do not use volatile liquid (such as thinner or gas) to clean the air conditioner. Otherwise, it may damage the appearance of air conditioner.

Clean outer case and grille

Clean outer case:

If there's dust on the surface of outer case, please use soft towel to wipe it. If the outer case is very dirty (such as grease), please use neutral abluent to wipe it.

Clean grille: Use cleaner or soft brush to clean it.

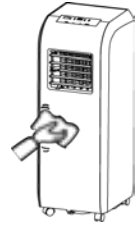

Clean filter

1 Remove the filter

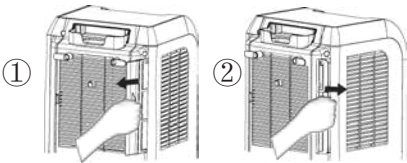

2 Clean filter

Use cleaner or water to clean the filter. If the filter is very dirty (such as grease), use warm water 40°C (104°F) melted with neutral abluent to clean it and then put at shady place to dry it.

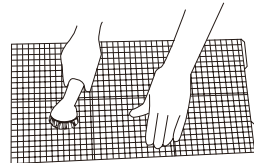

3 Install filter

After the filter is cleaned and dried, reinstall it well.

Note:

- The filter should be cleaned about once every three months. If there's much dust in the operation environment, you can increase clean frequency.
- Do not dry the filter with fire or hair drier. Otherwise, it may be deformed or catch fire.

Clean and Maintenance

Clean heat-removal pipe

Remove the heat-removal pipe from air conditioner, clean and dry it , and then reinstall it. (For the method of installation and removal method, please refer to the instruction for "Installation and disassembly of heat discharge pipe").

Checking before use-season

1. Check whether air inlets and air outlets are blocked.
2. Check whether plug and socket are in good condition.
3. Check whether filter is clean.
4. Check whether batteries is installed in remote controller.
5. Check whether joint, window bracket and heat-removal pipe are installed tightly.
6. Check whether heat-removal pipe is damaged.

Checking after use-season

1. Disconnect power supply.
2. Clean filter and outer case.
3. Remove dust and sundries on the air conditioner.
4. Eliminate accumulated water in chassis (refer to the section of "Drainage way" for details).
5. Check whether window bracket is damaged or not. If yes, please contact dealer.

Long-time storage

If you don't use the air conditioner for a long time, please maintain it by following steps for good performance:

- Make sure there's no accumulated water in chassis and the heat-removal pipe is disassembled.
- Pull out the plug and wrap the power cord.
- Clean the air conditioner and pack it well to prevent dust.

Notice for recovery

- Many packing materials are recyclable materials. Please deal with them through local recycle bin.
- If you want to throw away the air conditioner, please contact local division or consultant service center for the correct disposal method.

Malfunction analysis

Please check below items before asking for maintenance. If the malfunction still can't be eliminated, please contact local dealer or qualified professionals.

Phenomenon	Troubleshooting	Solution
Air conditioner can't operate	● Power failure?	● Wait after power recovery.
	● Is plug loose?	● Reinsert the plug.
	● Whether the air switch is tripped off or fuse is burnt?	● Ask professional person to replace air switch or fuse.
	● Is there's malfunction for the circuit?	● Ask professional person to replace circuit.
	● Whether the unit is restarted up after stopping immediately?	● Wait for 3min, and then turn on the unit again.
Poor cooling (heating)	● Is the power too low?	● Wait after voltage is resumed.
	● Whether the air filter is too dirty?	● Clean the air filter.
	● Whether the set temperature is proper?	● Adjust the temperature.
	● Whether door and window are closed?	● Close door and window.
Air conditioner can't receive signal from remote controller or remote controller is not sensible.	● Whether the unit is interfered seriously (such as static pressure, unstable voltage)?	● Please pull out the plug. Insert the plug after about 3min, and then turn on the unit.
	● Whether remote controller is within the receiving range?	● The receiving range of remote controller is 8m. Do not exceed this range.
	● Whether it's blocked by obstacles?	● Remove the obstacles.
	● Is sensitivity of remote controller low?	● Check the batteries of remote controller. If the power is low, please replace the batteries.
	● Whether there's fluorescence lamp in the room?	● Move the remote controller close to air conditioner. ● Turn off the fluorescence lamp and try it again.

Malfunction analysis

Phenomenon	Troubleshooting	Solution
No fan blowed out from air conditioner	<ul style="list-style-type: none"> • Whether air outlet or air inlet is blocked? 	<ul style="list-style-type: none"> • Eliminate the obstacles.
	<ul style="list-style-type: none"> • Under heating mode, whether indoor temperature is reached to set temperature? 	<ul style="list-style-type: none"> • Indoor unit will stop blowing fan after reaching to set temperature.
	<ul style="list-style-type: none"> • Whether heating mode is started up just now? 	<ul style="list-style-type: none"> • In order to prevent cold air, air conditioner will delay for a while to be started up, which is the normal phenomenon.
	<ul style="list-style-type: none"> • Whether evaporator is defrosted? (observe it by pulling out the filter) 	<ul style="list-style-type: none"> • It's the normal phenomenon. Air conditioner is defrosting. After defrosting is finished, it will resume operation.
Set temperature can't be adjusted.	<ul style="list-style-type: none"> • Whether the unit operates under auto mode? 	<ul style="list-style-type: none"> • Temperature can't be adjusted under auto mode.
	<ul style="list-style-type: none"> • Whether the required temperature exceeds the temperature setting range? 	<ul style="list-style-type: none"> • Temperature emperature setting range: 16°C-30°C .
There's off flavour	<ul style="list-style-type: none"> • There's off-flavour source in the room, such as furniture, cigarette etc. 	<ul style="list-style-type: none"> • Eliminate the off-flavour source. • Clean the filter.
There's abnormal sound during operation	<ul style="list-style-type: none"> • Whether the unit is interfered by thunder, radio, etc? 	<ul style="list-style-type: none"> • Disconnect power, put through the power again, and then turn on the unit again.
You can heard water-flowing sound	<ul style="list-style-type: none"> • Whether the unit is turned on or turned off just now? 	<ul style="list-style-type: none"> • There's flowing sound of refrigerant inside the air conditioner, which is the normal phenomenon.
You can heard the sound of "PAPA"	<ul style="list-style-type: none"> • Whether the unit is turned on or turned off just now? 	<ul style="list-style-type: none"> • Heat expansion or shrinkage for the panel due to change of temperature, which cause friction sound.

Malfunction analysis

Malfunction code

E5	Overcurrent protection.	Disconnect power, and then turn on the unit again after 10min. If "E5" still exists, please contact professional person to maintain the unit.
H8	Chassis is full of water.	1. Pour out the water inside chassis. 2. If "H8" still exists, please contact professional person to maintain the unit.
F1	Malfunction of ambient temperature sensor.	Please contact previsual person to deal with it.
F2	Malfunction of evaporator temperature sensor.	Please contact previsual person to deal with it.
F0	1.Refrigerant is leaking 2.System is blocked	1. Re-energize the unit after turning off and pulling out the plug for 30min; 2. If there's still malfunction, please contact after-sales service.
H3	Overload protection for compressor	1.Check if the unit is under high-temperature and high-humidity environment; if ambient temperature is too high, power off the unit and then energize it for operation after the ambient temperature drops to 35℃below. 2. Check if the evaporator and condenser are blocked by some objects; if yes, take away the objects, power off the unit and then energize it for operation. 3. If the malfunction still occur, please contact our after-sales service center.
E8	Overload malfunction	
F4	Outdoor tube temperature sensor is open/short-circuited.	Please contact after-sale service person to deal with it.

Warning

- If there're below phenomenons, please turn off the air conditioner and disconnect the power immediately, and then contact dealer immediately.
 - Power cord is overheating or damaged.
 - Abnormal sound during operation.
 - Off-flavor.
 - Water leakage
- Do not repair or refit the air conditioner by yourself.
- If operate the air conditioner under abnormal condition, it may cause malfunction, electric shock or fire hazard.

Installation Precaution



Warning:

- Observe all governing codes and ordinances.
- Do not use damaged or non-standard power cord.
- Be caution during installation and maintenance. Prohibit incorrect operation to prevent electric shock, casualty and other accidents.

Selection of Installation Location

Basic requirement

Installing the unit in the following places may cause malfunction. If it is unavoidable, please consult the local dealer:

1. The place with strong heat sources, vapors, flammable or explosive gas, or volatile objects spread in the air.
2. The place with high-frequency devices (such as welding machine, medical equipment).
3. The place near coast area.
4. The place with oil or fumes in the air.
5. The place with sulfureted gas.
6. Other places with special circumstances.

Requirement of air conditioner

1. Air inlet should be far away from obstacles and do not put any objects near air outlet. Otherwise, it will affect the radiation of heat-removal pipe.
2. Select a location where the noise and outflow air emitted by the outddor unit will not affect neighborhood.
3. Please try your best to keep far away from fluorescent lamp.
4. The appliance shall not be installed in the laundry.

Requirements Forelectric Connection









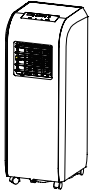
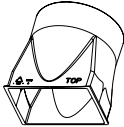

Safety precaution

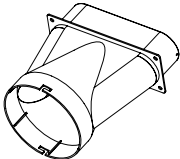
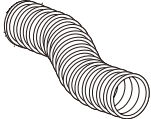
1. Must follow the electric safety regulations when installing the unit.
2. According to the local safety regulations, use qualified power supply circuit.
3. For appliances with type Y attachment, the instructions shall contain the substance of the following. If the supply cord is damaged, it must be replaced by the manufacturer, its service agent or similarly qualified persons in order to avoid a hazard.
4. Properly connect the live wire, neutral wire and grounding wire of power socket.
5. Be sure to cut off the power supply before proceeding any work related to electricity and safety.
6. Do not put through the power before finishing installation.
7. The air conditioner is first class electric appliance. It must be properly grounding with specialized grounding device by a professional. Please make sure it is always grounded effectively, otherwise it may cause electric shock.
8. The yellow-green wire or green wire in air conditioner is grounding wire, which can't be used for other purposes.
9. The grounding resistance should comply with national electric safety regulations.
10. The appliance shall be installed in accordance with national wiring regulations.



Preparation before installation

Note: check if the accessories are available before installation.

Accessory list

 unit	 joint A	 joint B	 joint C	
 heat discharge pipe	 screw(1)	 pipe clip	 rubber plug	 pipe hoop (2)
 drainage pipe	 remote controller	 battery (2) (AAA 1.5V)		 user's manual

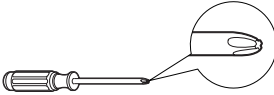
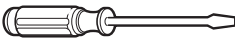
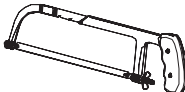
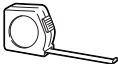
Tools needed for installation

 cross screwdriver	 straight screwdriver	 saw
 gauge	 scissors	 pencil

Install drainage pipe

Note: Install drainage pipe before using, otherwise poor drainage will affect normal operation of the unit.

1. Remove the rubber plug at drainage port.

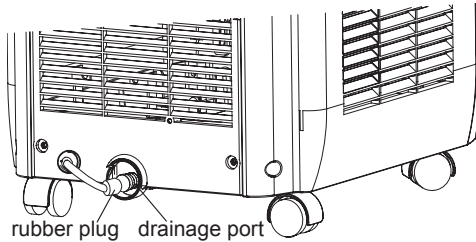

2. Fix the drainage pipe clip on the right of rear side plate near drainage port with a screw.

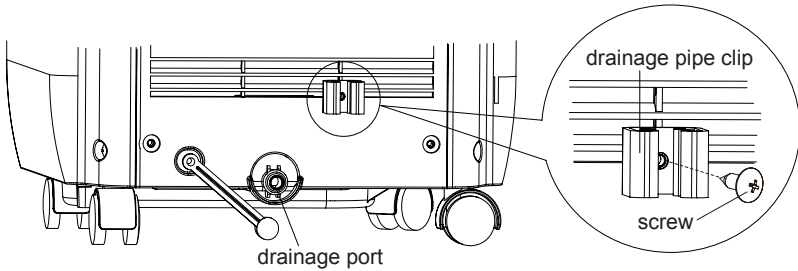

3. Put the drainage pipe into drainage port and screw it up, and then bind it with pipe hoop.
4. Put the rubber plug into the other side of drainage pipe, fix it with pipe hoop and then fix it in the drainage pipe clip.

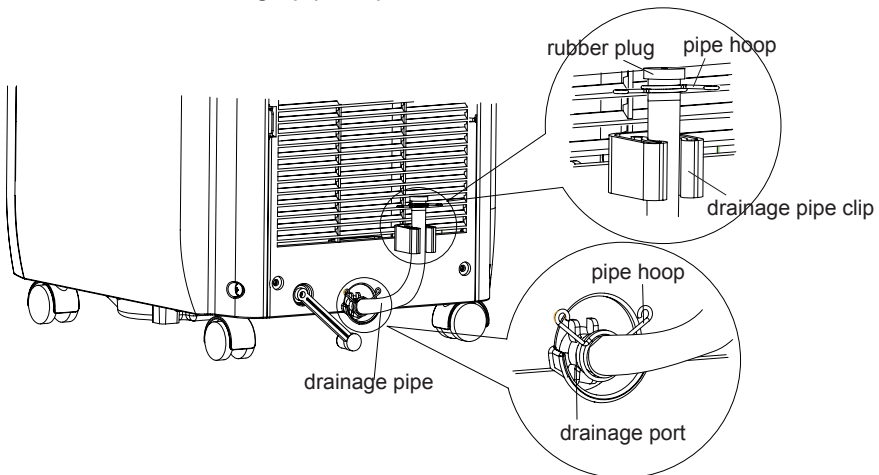

Installation and disassembly of heat discharge pipe

Install heat discharge pipe

1. Rotate joint A and joint B clockwise into the two ends of heat discharge pipe.

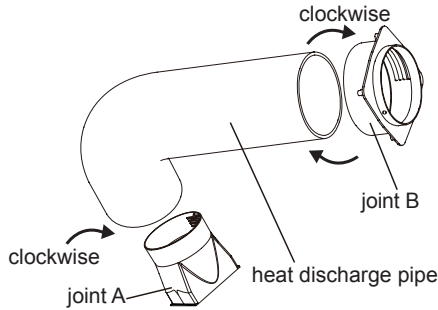

2. Insert joint A of heat discharge pipe (the side with "TOP" is upwards) into the groove until you hear a sound.

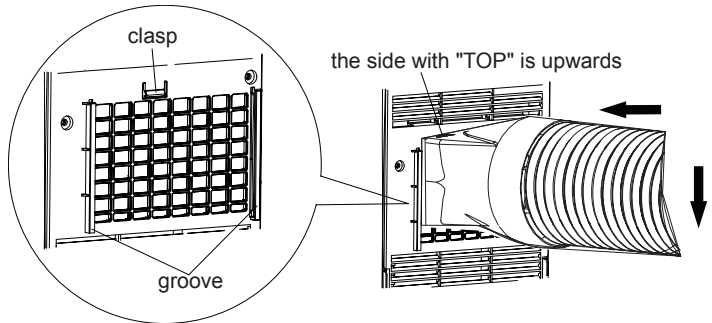

3. Aim the locating pole of joint B of heat discharge pipe at the opening of joint C; rotate it slightly to make joint B and joint C connect tightly.

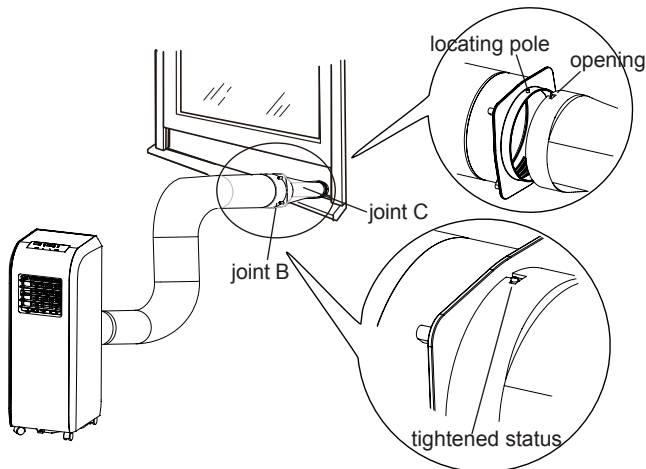

Installation and disassembly of heat discharge pipe

Note of Install heat discharge pipe

In order to improve cooling efficiency, the heat discharge pipe should be as short as possible and flat without curve to ensure smooth heat discharge.

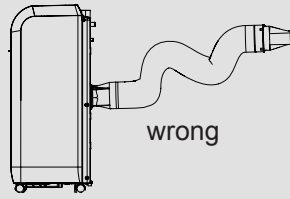
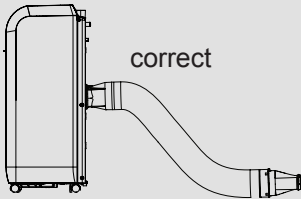
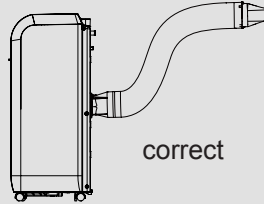
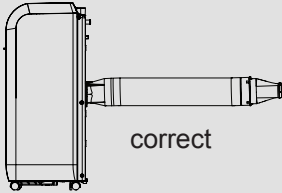

- The length of the exhaust pipe is less than 1m. It is recommended to use it with shortest length.
- When installing, exhaust pipe should be as flat as possible. Don't prolong the pipe or connect it with other exhaust pipe.

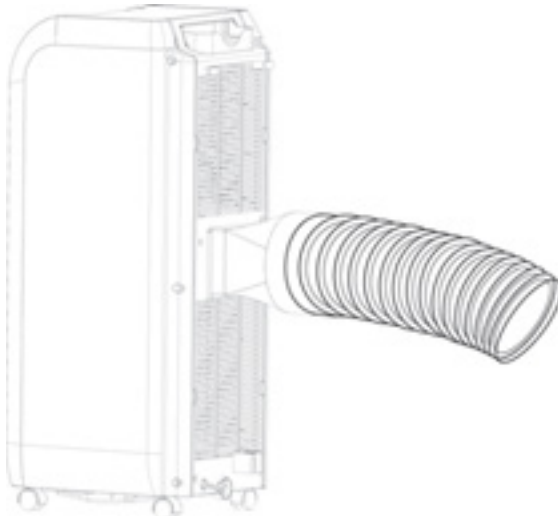

Installation and disassembly of heat discharge pipe

- Correct installation is as shown in figure (When installing it on wall, height of hall should be about 40cm-130cm from floor).

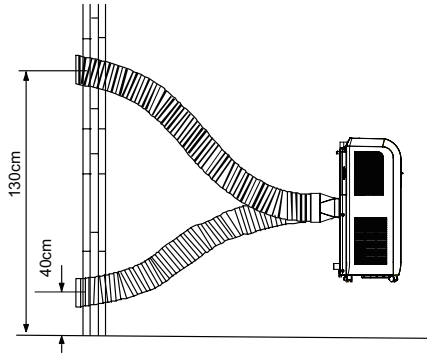

- Wrong installation is shown in following figure (If the pipe is bent too much, it would easily cause malfunction.)

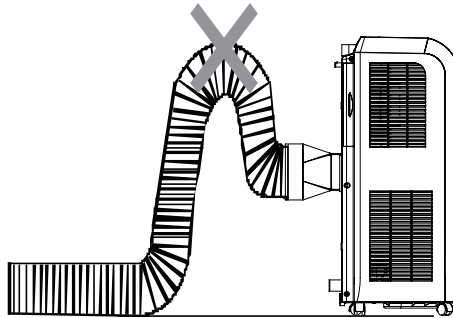

Disassemble heat discharge pipe

1. Remove joint B:
remove joint B from joint C.

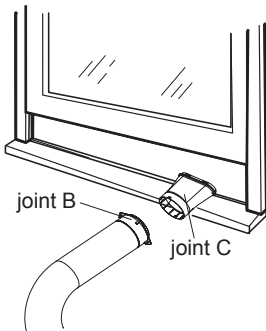

2. Remove joint A:
Press the clasp and lift joint A upwards to remove it.

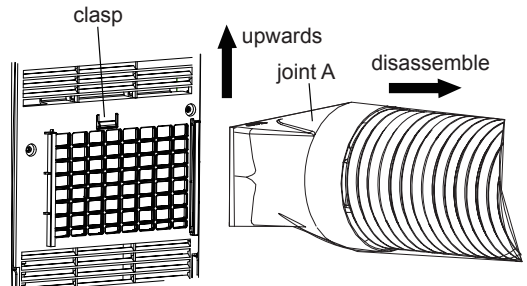

Operation test

- Put through the power supply and then press ON/OFF button on remote controller to start the unit.
- Press mode button to select auto, cooling, drying, fan or heating function, and then check if the unit operates normally.
- If ambient temperature is below 16°C, the unit can't operate in cooling mode.

Drainage way

- In cooling or drying operation, the condensation water will be drained to the chassis and spattered by water-striking motor. As the temperature of condenser is high, most of the condensation water will be evaporated and drained to outdoor. So usually, only a little condensation water will be accumulated inside the chassis and you do not need to discharge the water frequently.
- When the chassis is full with water, the buzzer will give out 8 sounds and "H8" is displayed to remind user to discharge water:
 - Move the unit to a suitable place for discharging water; do not tilt the unit and keep it horizontal during moving;
 - Take the drainage pipe from the clip and pull out the rubber plug on the drainage pipe to discharge water;
 - Put back the rubber plug onto drainage pipe after finishing discharging water and then fix the pipe on the clip;
 - After full water protection is eliminated and the compressor has been stopped for 3 minutes, the unit will resume operation.

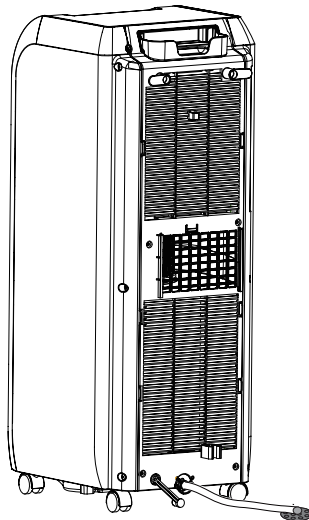

Electric schematic diagram

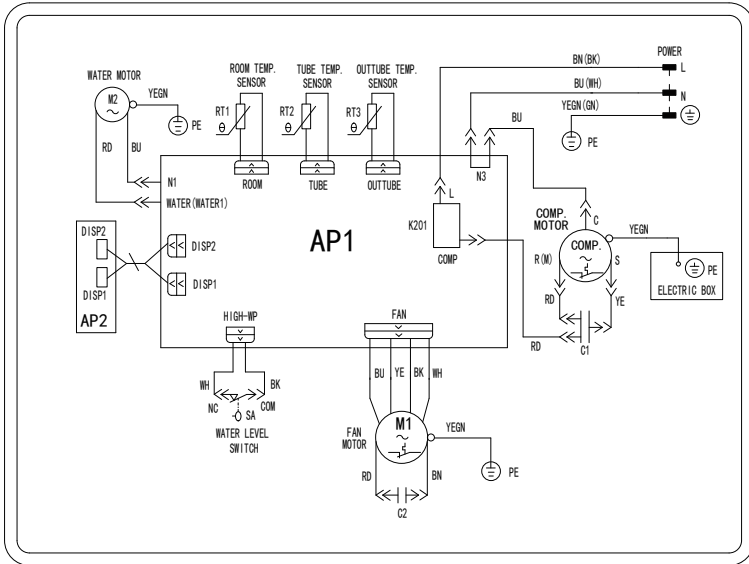



inventor[®]

Your-conditions

